

CART SERIES

TASK, INSPECTION, HAZARDOUS AREAS

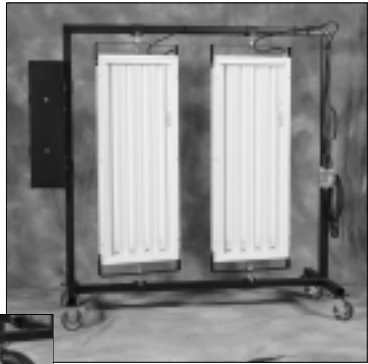

4 Ft. 2 Fixture Cart



Standard 10" pneumatic tires

Shown with optional tool tray and 5" casters

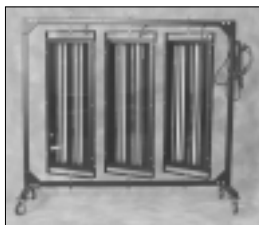

Call LDPI® for a quote on a cart with 3 or 4 fixtures.



Fixture: ETL listed. U.S. and Canada
Class I Div. 2, Groups A, B, C and D
Class II Div. 2, Groups F and G

FEATURES

2 FIXTURE CART: P/N 3668
Black finish with standard swivel mounting brackets and 10" pneumatic tires (2) swivel (2) non-swivel
25' power cord with 15 amp 120 volt NEMA rated plug

CART OPTIONS
Vertical or horizontal fixture mount (2 fixture cart only)
Outlet box with 1 duplex outlet
Only on 120V carts
5" casters (polyurethane) (2) swivel (2) non-swivel
Tool tray with adjustable shelves P/N 4362
NEMA rated power cord plug, other than specified, can be provided. Call for pricing.

POWER REQUIREMENTS/OPTIONS
Voltage: 120 volts or 277 volts
Amperage: 15 amps or 20 amps

FIXTURE OPTIONS
Inspection 390420INS-3613
Class I and II Division 2 Industrial 390440H-3546
Open Industrial Task Lighting 390440I-3546

OPEN INDUSTRIAL LIGHT OPTIONS
Polycarbonate Lens P/N 4448
Protect-A-Lamp Guards P/N 4154
F32 T-8 Lamp, 5000K P/N 3114
(recommended)

SPECIFICATIONS

The 2 or 3 Fixture Portable Lighting Cart is designed to accept the listed light fixtures mounted either vertically or horizontally (horizontal mounting available only on two fixture cart). Fixtures are attached with swivel mounting brackets allowing for directional aiming of the light. Cart rolls easily on the standard 10" pneumatic tires, two fixed and two swivel, and has a 15 amp 120 volt power cord.

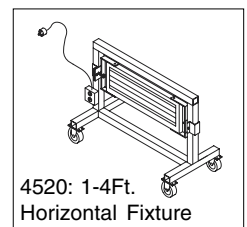

4520: 1-4Ft. Horizontal Fixture

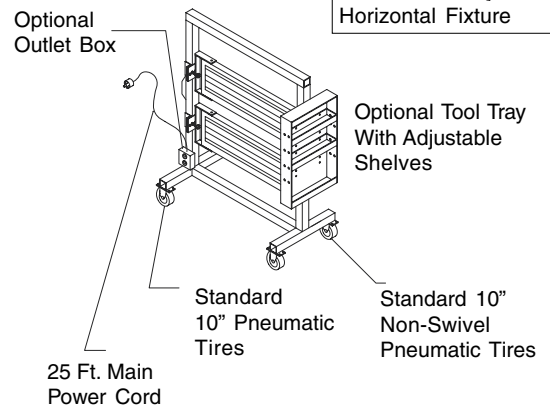
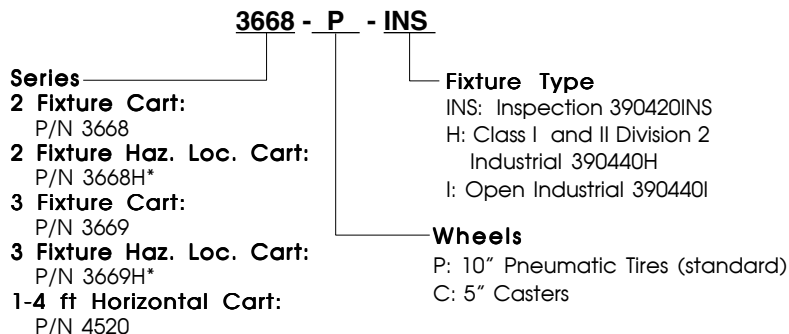

*P/N 3668H and 3669H are Class I Div. 2 Hazardous Location carts are assembled with a stationary fixture mounting bracket.