

4 Ft. Single Fixture Cart



Fixture: ETL listed. U.S. and Canada
Class I Div. 2, Groups A, B, C and D
Class II Div. 2, Groups F and G
390440H ONLY

FEATURES

2 WHEEL VERTICAL CART: P/N 4346
8" semi-pneumatic ball bearing wheels
20' Power cord (specify voltage and amperage)
Cords can be supplied with NEMA rated power cord
plugs. (specify amperage)

CART OPTIONS
Shelf Trays: 20 1/2" W x 8" D x 3" H P/N 4344
Cord Reel Non-Hazardous 20 FT P/N 4826

POWER REQUIREMENTS
Voltage: 120 volts or 277 volts

FIXTURE OPTIONS
Inspection 390420INS-3613
Class I and II Division 2 Industrial 390440H-3546
Task/Open Industrial 390440I-3546

OPEN INDUSTRIAL OPTIONS
Polycarbonate Lens P/N 4448
Protect-A-Lamp Guard P/N 4154
F32-T-8 Lamp, 5000K P/N 3114
(Recommended)

SPECIFICATIONS

The single fixture light cart is designed to provide portable lighting solutions for applications ranging from inspection to laboratory and general industrial task lighting. Light fixture options allow you to customize your cart to fit your work application requirements.

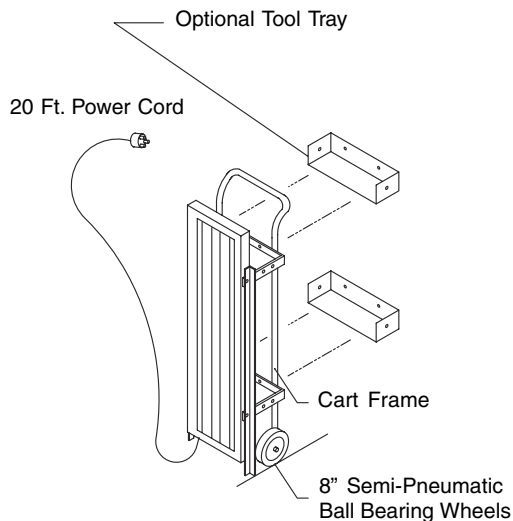

4346 - INS

Series

2 WHEEL PORTABLE CART:
P/N 4346

8" semi-pneumatic ball bearing wheels
20' Power Cord (specify voltage and amperage)

Fixture Type

INS: Inspection 390420INS
H: Class I and II Division 2 Industrial 390440H
I: Open Industrial 390440I